

## ■ GMSW 尺寸表 (DIMENSIONS)

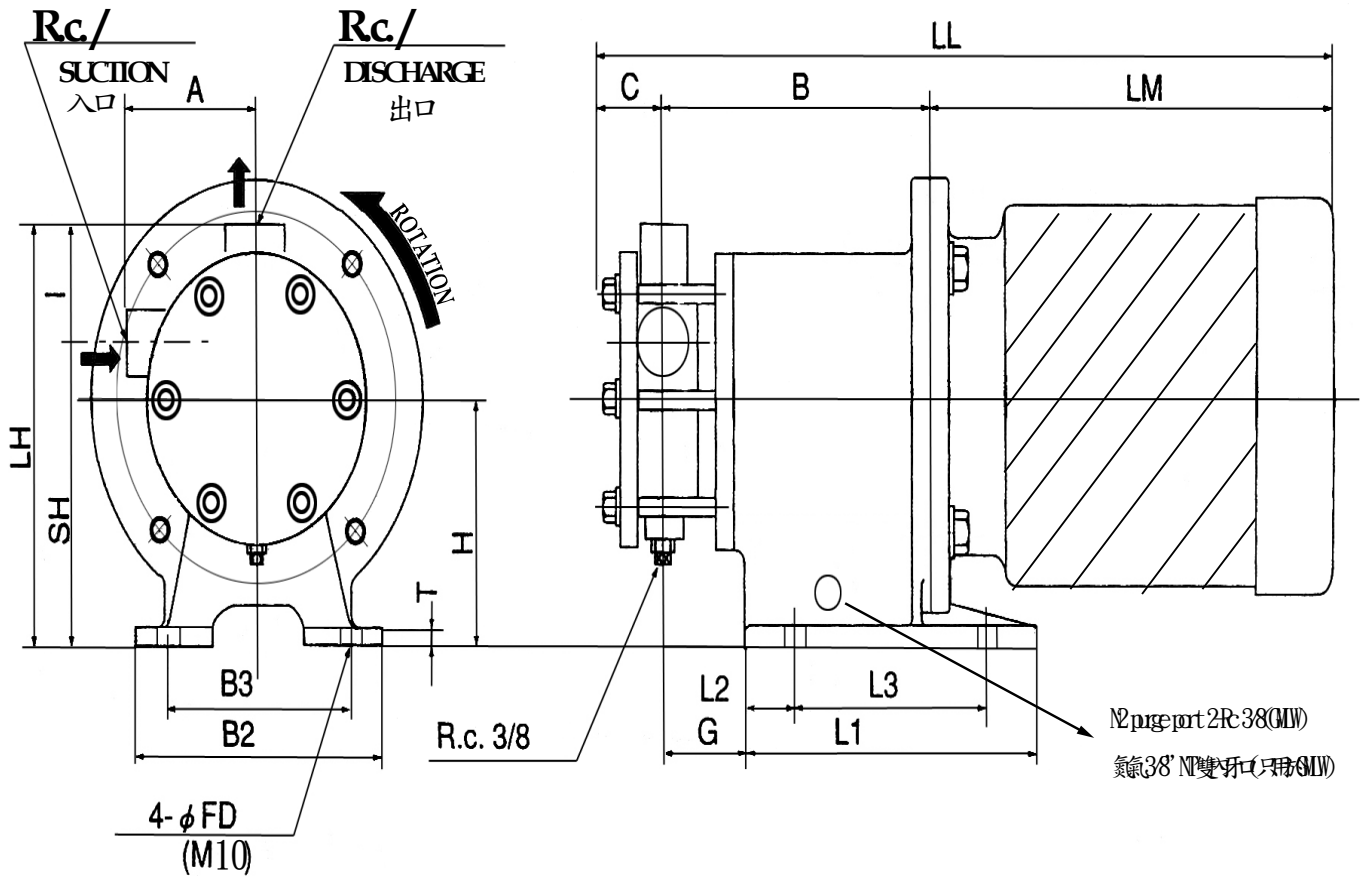

單位:mm

型號 PUMP SIZE	馬達 MOTOR		口徑 BORE		泵和馬達 PUMP & MOTOR DIMENSION										馬達座 BASE PLATE						重量 WEIGHT APPROX (kgf)			
	框號 FRAME SIZE	輸出 OUT PUT (Kw)	Ds	Dd	A	B	C	H	I	SH	LH	LM	LL	G	L1	L2	L3	B2	B3	T	FD	PUMP	MOTOR	TOTAL
GMSW201-S	80	0.75	(20)	(20)	80	170	35	110	55	135	190	242	447	80	180	30	120	160	130	12	12	20	18	38
	90L	1.5	Rc3/4	Rc3/4	80	170	35	110	55	135	190	321	526	80	180	30	120	160	130	12	12	20	25	45
GMSW201	80	0.75	(20)	(20)	80	170	35	170	55	200	255	242	447	80	250	30	190	200	160	18	12	25	18	43
	90L	1.5	Rc3/4	Rc3/4	80	170	35	170	55	200	255	321	526	80	250	30	190	200	160	18	12	25	25	50
GMSW251-S	90L	1.5,2.2	(25)	(25)	105	170	40	110	75	140	215	321	531	80	180	30	120	160	130	12	12	20	25	45
	100L	2.2	Rc1	Rc1	105	180	40	170	75	200	275	315	535	80	250	30	190	200	160	18	12	25	28	53
GMSW251	90L	2.2	(25) (Rc1)	(25) (Rc1)	105	170	40	170	75	200	275	315	525	80	250	30	190	200	160	18	12	25	25	50
GMSW252-S	90L	2.2	(25)	(25)	105	170	40	110	75	140	215	321	531	80	180	30	120	160	130	12	12	20	25	45
	00L)112	2.2,3.7	Rc1	Rc1	105	180	40	170	75	200	275	371	591	80	250	30	190	200	160	18	12	25	48	73
GMSW252	90L	2.2	(25)	(25)	105	170	40	170	75	200	275	315	525	80	250	30	190	200	160	18	12	25	28	53
	112M	3.7	Rc1	Rc1	105	180	40	170	75	200	275	371	591	80	250	30	190	200	160	18	12	25	48	73

※ LM,LL dimensions and motor weight way vary depending on motor used。LM與LL尺寸與重量會依廠牌不同而改變。

※ This motor size and weight, begin TECO motor as the basis。此表馬達尺寸與重量,皆以東元馬達為依據。